

Les Produits MURPHCO Ltée

TECHNICAL DATA

MURPHCO ULTRA ROOF DRAINS

DESCRIPTION

ULTRA COPPER DRAIN

d :
2"
2 5/8"
3"
3 5/8"
4"
4 5/8"
5"
5 5/8"
6"

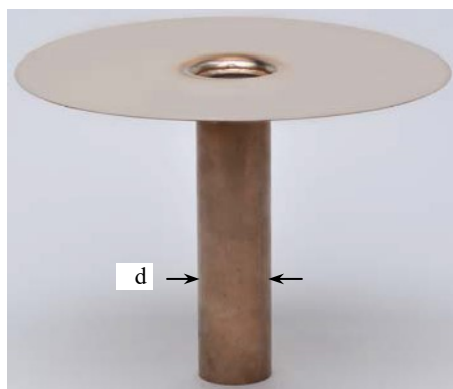

ULTRA ALUMINUM DRAIN

d :
2 5/8"
3"
3 5/8"
4"



The design of the joint between the flange and the sleeve makes it a very distinctive roof drain. The flange is folded down in the sleeve with the patented *Murphco* punch. Both pieces are then unified with a continuous **"MIG"** bronze solder joint, under the flange. This solder joint cannot be melted when heated by a blowtorch at the time of application of modified bitumen membranes so that the assembly remains permanently watertight. This method avoids any contact of water on the soldered joint, preventing any infiltration on account of solder defect.

Use: recommended for all types of flat roofs: industrial, commercial, and residential.

MATERIALS

	ULTRA COPPER DRAIN	ULTRA ALUMINUM DRAIN
FLANGE	32 oz copper, thickness : 0.042" (1.066 mm)	Rigid aluminum 3003-H14, MARINE TYPE; Thickness: 0.090" (2.29 mm)
SLEEVE	Rigid copper sleeve See table of diameters, page 3	Rigid aluminum sleeve, 3003-H14 grade, MARINE TYPE; ALLOY 6061 : 0.090" (2.29 mm) thick for all interior diameter sizes See table of interior diameters, page 3
STANDARDS	Rigid copper sleeve conforming with ASTM-B75	Rigid aluminum sleeve conforming with ASTM-B221.REV.14
GRADE	Commercial, DHP C12200	Marine vessels, pressure tanks
SOLDER	"MIG" process	"MIG" process

DIMENSIONS

	ULTRA COPPER DRAIN	ULTRA ALUMINUM DRAIN
FLANGE	CIRCULAR 16" DIA. (400 mm); square flange on request. (delivery delay)	CIRCULAR 16" DIA. (400 mm)
SLEEVE	Standard length: 12" (300 mm) and 18" (452 mm); longer sleeves available on request (delivery delay)	Standard length: 12" (300 mm) and 18" (452 mm); longer sleeves available on request (delivery delay)

MURPHCO ULTRA ROOF DRAINS

INSTALLATION – COPPER DRAIN / ALUMINUM DRAIN

At the membrane level:

These types of roof drains are used on flat roofs covered with B.U.R. asphalt felt membranes, modified bitumen or E.P.D.M. roofing and waterproofing membranes.

To seal the drain to the membrane, it is recommended to prime the copper and/or aluminum flange on both sides with a compatible primer. Then, the flange is applied into a continuous layer of compatible and heavy duty bituminous cement, or specified adhesive.

To complete the flashing of the flange to an asphalt felt membrane, apply 2 plies of heavy duty cotton fabric and a top ply no.15 asphalt felt, each one applied into hot bitumen.

For a modified bitumen membrane, apply a reinforcing ply and extend the cap sheet membrane in accordance with the recommendation of the manufacturer.

For an E.P.D.M. membrane, strictly follow the installation procedures recommended by the membrane manufacturer.

Connection to the interior rainwater leader:

The connection of the roof drain sleeve to the interior rainwater leader may be made as per the following procedures:

1. If the rainwater leader is accessible by the interior, cut the roof drain sleeve to an appropriate length in order to install a clamp collar with 3" and 4" drains or a flexible coupling sleeve. This method may be made only with a rigid sleeve roof drain. In such a way. The water flow diameter is not reduced.
2. When using an appropriate interior drain diameter of 2 $\frac{5}{8}$ " (67 mm), 3 $\frac{5}{8}$ " (92 mm), 4 $\frac{5}{8}$ " (117 mm) and 5 $\frac{5}{8}$ " (143 mm), the drain sleeve may also be sealed to the interior pipe with a U-Flow^{T.M.} seal, following the recommendation of U-Flow Inc., manufacturer.
3. The drain sleeve may also be sealed to the interior pipe with a heavy duty elastomeric cement applied on the exterior surface of the sleeve, before the drain installation. This interior pipe connection method is used only if the methods described in items 1 and 2 above are not possible.

FEATURES AND GUARANTY

- Rigid copper or aluminum sleeve without joint, clip or vertical solder
- 32 oz copper flange or 0.090" (2.29 mm) aluminum flange folded down in the sleeve with the patented *Murphco* punch
- No joint or solder exposed to surface water
- Compatible with U-FLOW^{T.M.} seal, clamp collar or flexible coupling sleeve for a maximum flow
- Durability, quality and commercial grade
- Guaranteed against corrosion and manufacturing defects (see note)

Note: Avoid any contact between the aluminum drain and pressure treated wood. Such contact shall invalidate the drain guaranty.

MURPHCO ULTRA ROOF DRAINS

DRAIN SECTION – COPPER DRAIN / ALUMINUM DRAIN

Scale: 1:5

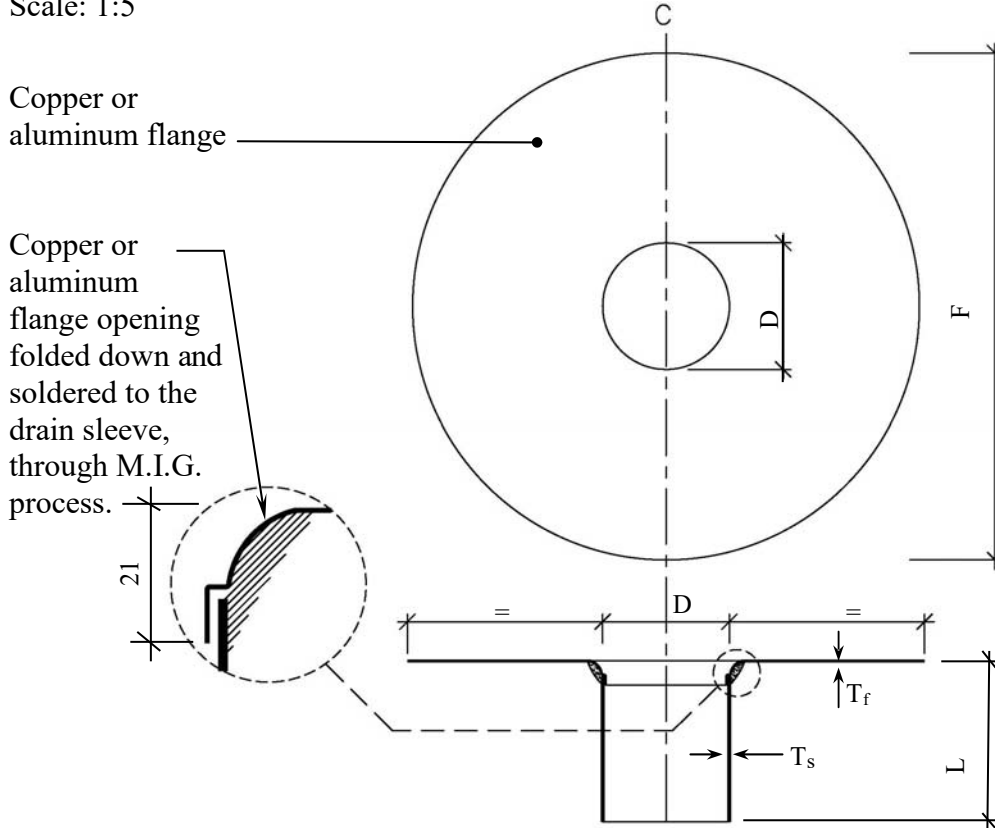

ULTRA COPPER DRAIN				
STANDARDS DIMENSIONS				
D (interior)	T _s	T _f	F	L
2" (51 mm)	0.050" (1.27 mm)	32 onces	Round 16" (400 mm)	12" & 18" (300 & 452 mm)
2 5/8" (67 mm)	0.050" (1.27 mm)	32 onces		
3" (76 mm)	0.045" (1.14 mm)	32 onces		
3 3/8" (92 mm)	0.078" (1.83 mm)	32 onces		
4" (102 mm)	0.058" (1.47 mm)	32 onces		
4 3/8" (117 mm)	0.090" (2.29 mm)	32 onces		
5" (127 mm)	0.090" (2.29 mm)	32 onces		
5 5/8" (143 mm)	0.090" (2.29 mm)	32 onces		
6" (152 mm)	0.090" (2.29 mm)	32 onces		

ULTRA ALUMINUM DRAIN				
STANDARDS DIMENSIONS				
D (interior)	T _s	T _f	F	L
2 5/8" (67 mm)	0.090" (2.29 mm)	0.090" (2.29 mm)	Round 16" (400 mm)	12" & 18" (300 & 452 mm)
3" (76 mm)	0.090" (2.29 mm)	0.090" (2.29 mm)		
3 3/8" (92 mm)	0.090" (2.29 mm)	0.090" (2.29 mm)		
4" (102 mm)	0.090" (2.29 mm)	0.090" (2.29 mm)		

MURPHCO ULTRA ROOF DRAINS

TYPICAL DETAIL – COPPER DRAIN / ALUMINUM DRAIN

Scale: 1:5

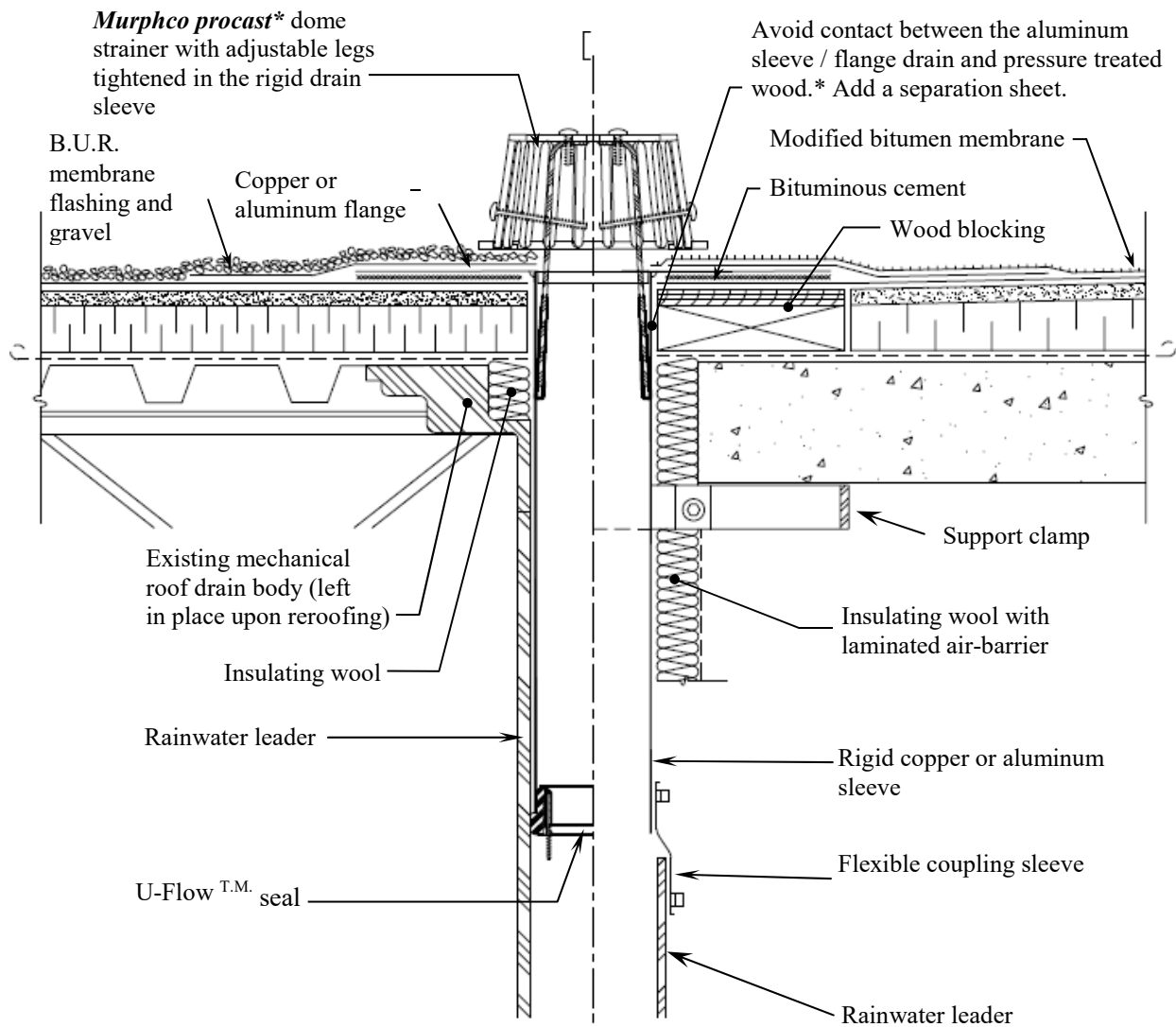

Notice to plumbing / roofing contractor: When a copper drain sleeve must be cut for adjustment to appropriate length, avoid the use of vibrating tools that could generate fissures in the copper flange or sleeve along the solder. Rather utilize a circular cutter.

*Note: Avoid any contact between the aluminum drain and pressure treated wood. Such contact shall invalidate the drain guaranty.

Les Produits MURPHCO Ltée

TECHNICAL DATA

MURPHCO ULTRA ROOF DRAINS

DESIGNED AND MANUFACTURED BY LES PRODUITS MURPHCO LTÉE

Technical assistance or further information may be obtained from:



Manufacturier et spécialiste de drains de toiture

Boutique de Métal en feuille

4955 Brock st, Montreal (Qc) H4E 1B5

Tel.: (514) 937-3275 • Fax: (514) 937-6797

Web: www.produitsmurphco.com • E-mail: nancy@produitsmurphco.com

DOCUMENTATION PRÉPARÉE AVEC LA COLLABORATION TECHNIQUE DE :

Englobe

1200, boul. Saint-Martin Ouest, bureau 400

Laval (Québec) H7S 2E4

T 514.281.5173

F 450.668.5532

info@englobecorp.com

NOTICE

The information and specification provided in this document are applicable at time of publication. They are condensed from the exact results obtained through real tests and field experience, but may not be construed as implying any absolute and final dictate on our part. **Les Produits MURPHCO Ltée**. Reserves the right to modify, without notice, the information provided in the present document, as a result of its research and development policy on its product.